

IMPORTANT: PLEASE FOLLOW THESE INSTRUCTIONS TO ENSURE WE SUPPLY THE CORRECT BIDET

1. Please bring a **measuring tape** and **gloves**.
2. **Please take 3 photographs of the toilet area**, above the toilet, 1 of the entire toilet area, 1 showing the water supply inlet on the wall, also **1 Photo** of the power box to ensure it has an **RCD switch**.
3. **When completed** please submit via email to ot@thebidetshop.com.au or if you require help with the completion of the form while at the clients home please feel free to Call 1300 243 387.



REMOTE EVALUATION CHECK LIST - Please Answer All Questions

| | | | | | |
|------------------------|---------|--------------------------------------|--------------|------------|--|
| 1. Client Details | | | | | |
| Client Name | | | Phone Number | | |
| Postal Address | | | | | |
| Suburb | | Postal Code | | State | |
| Is your client a DVA? | DVA No. | If not then what fund are they with? | | Fund Group | |
| Occupational Therapist | | O.T Ph. | | O.T. Email | |
| Bidet delivery to | | Client | Plumber | | |

2. Toilet Measure & Check

| | | | | | |
|---|--|---|------|------------|---------|
| <p>PLEASE TAKE PHOTOS OF TOILET </p> <p>See page 2-3 Diagrams for more Information</p> | <p>(I) Toilet Measurements</p> <p>(A / A.1) mm</p> <p>(B) mm</p> <p>(C) mm</p> <p>(D) mm</p> | <p>PLEASE TAKE PHOTOS OF TOILET </p> <p>See page 2-3 Diagrams for more Information</p> | | | |
| | <p>(II) Where is the water tap located?</p> <table border="1"> <tr> <td>Wall</td> <td>In Cistern</td> <td>Outside</td> </tr> </table> <p>(III) Access to the toilet seat bolts is from...</p> <table border="1"> <tr> <td>Underneath</td> <td>Top Only</td> </tr> </table> | | Wall | In Cistern | Outside |
| Wall | In Cistern | Outside | | | |
| Underneath | Top Only | | | | |

| | | | | | | | | |
|------------------|--------|-------|--|-----|----|---------------------|-----|----|
| Toilet bowl type | SQUARE | ROUND | Is there a lip at the back of the toilet bowl? | YES | NO | Pedestal is secure? | YES | NO |
|------------------|--------|-------|--|-----|----|---------------------|-----|----|

3. Toilet Location

| | | | | | | |
|--|-----|-----|-------------------------------|--|-----------|--------|
| Is the toilet in the bathroom? | YES | NO | What level is the toilet on? | Ground | Lvl1 | Lvl2+ |
| Are the walls fully tiled? | YES | NO | Home uses town water? | YES | NO | |
| Power point installation needed? | YES | NO | Home is double brick? | YES | NO | |
| Shower head on flexible hose? | YES | NO | Is the home in a remote area? | YES | km to CBD | NO |
| Shower screen/curtain between shower & toilet? | | YES | NO | If 'NO' Distance from shower head to toilet? | | metres |

4. Client Requirements

Please choose the required extras that will be needed

| | | | | | | |
|-----------------------------------|---------------------|------|---------------|-----------|---------------|----|
| Ability to lower/lift themselves? | YES | NO | Client Height | cm | Client weight | kg |
| Raisers | 50mm | 80mm | Arms | 3 in 1 | Bariatric | |
| Remote Holder | Tamper Proof Holder | | Splash Guard | Pee Guard | | |

5. Plumbing Requirments - 80mm Raiser **or** RPZ Valve Installation (to comply with plumbing code AS/NZS 3500, **see p.3**)

IF no 80mm raiser is selected above **THEN** an 'RPZ Valve' **MUST** be installed. RPZ REQUIRED YES NO

6. RCD Power box

All homes under 15yrs old should have this as standard.

| | | | |
|--------------------------------------|-----|----|--|
| Does the home have an RCD Fitted? | YES | NO | <p>RCD EXAMPLE PLEASE TAKE A PHOTO</p> |
| How old is the house? | yrs | | |
| Is an internal fitting kit required? | YES | NO | |

GUIDE - Locating Measurements / Water tap / Seat bolts

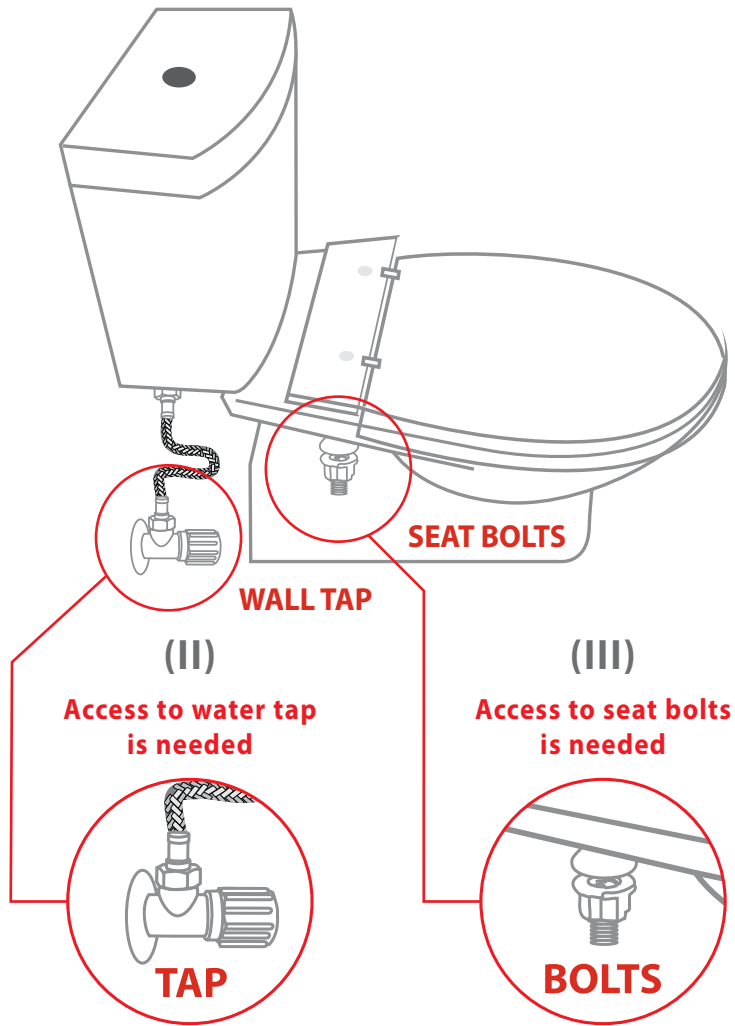
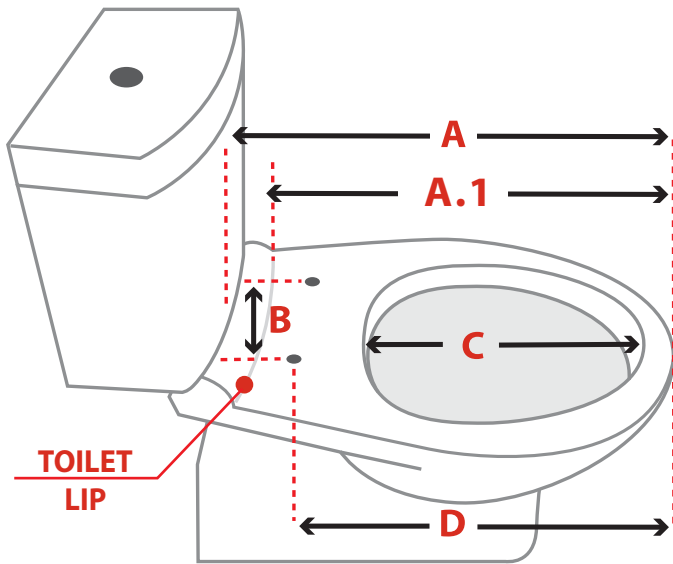

(I)

Fitting measurements needed

- (A) Front (centre) of cistern to front (centre) of bowl
- (B) Centre to centre of bolt holes
- (C) Back (inside centre) to front (inside centre) of bowl
- (D) Bolt holes to front of bowl

(A.1) If toilet bowl is not flat all the way to the cistern (lip) measure from the lip to front (centre) of bowl.

(II)

Access to water tap is needed

TAP

(III)

Access to seat bolts is needed

BOLTS

Some toilets may not have access to seat bolts from underneath see **STYLE GUIDE** below

STYLE GUIDE - Close Coupled / Back To Wall / Wall Hung

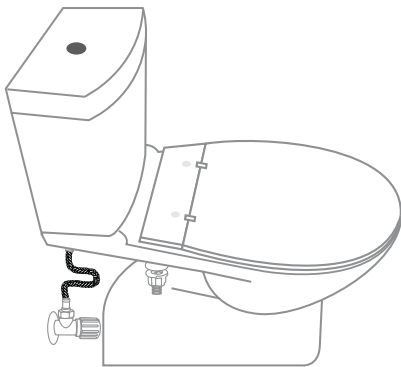

Close coupled toilet

(Often have a lip at the back of pan)

Close Coupled Toilets, most have curved lips at back of pan to cistern, a measurement front of cistern to front edge of pan NEEDS TO BE A LEVEL measurement.

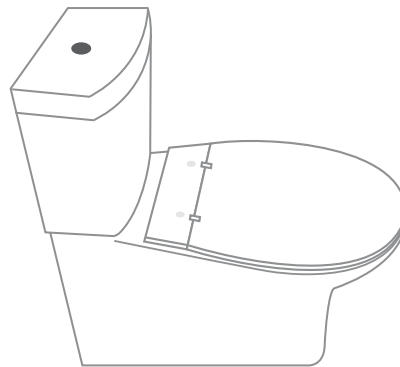

Back To Wall suites

(often no bolt access from underneath TOP FIXING BOLTS REQUIRED)

A modern style, often there is no access to the seat bolts from underneath in this style.

If the water supply tap is inside the cistern/tank then an internal fitting kit is required, please state on the order.

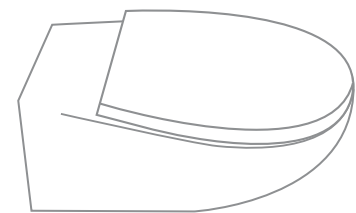

Wall Hung suites

(often no bolt access from underneath TOP FIXING BOLTS REQUIRED)

Some have access to seat bolts. Will fit most Round Seats, water access to be determined.

If the water supply tap is inside the inside wall then a separate cistern tap is required for water feed to bidet. If this cannot be done then alternative solutions from nearby water source will be discussed.



PHOTO GUIDE - Below are examples of photos needed



**PHOTO 1
EXAMPLE**



TOILET AREA

**PHOTO 2
EXAMPLE**



ABOVE TOILET

**PHOTO 3
EXAMPLE**

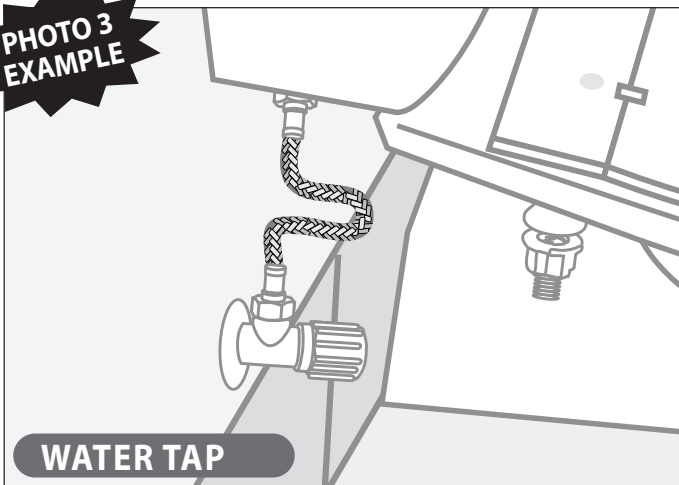

WATER TAP

**PHOTO 4
EXAMPLE**

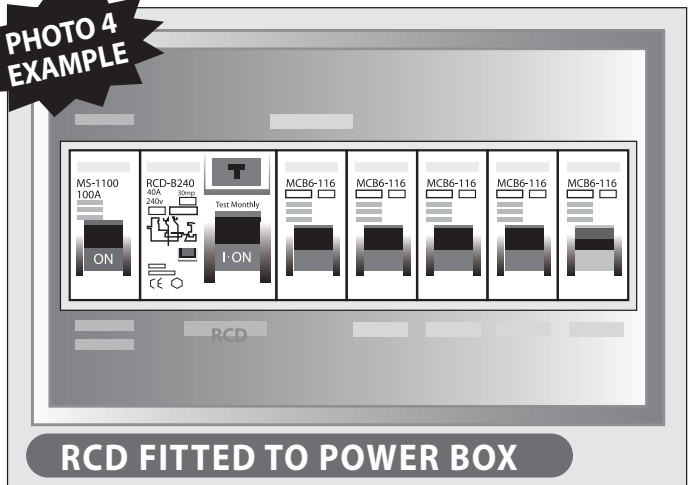

RCD FITTED TO POWER BOX

INSTALLATION & PLUMBING - AS 3500.1

IF no 80m m raiser is being installed **THEN** an 'RPZ Valve' **MUST** be installed.

Plumbing Regulations as per AUS/NZ standards

A toilet seat douche or bidet must comply with AS/NZS 3500 Part 1 Water Services Clause 12.2.3.

A douche outlet installed at least 25mm above the overflow level of the pan, at any position, does not require a backflow prevention device. If the douche outlet is less than 25mm above the overflow level of the pan, at any position, a 'high hazard' backflow prevention device must be installed. The device must comply with AS/NZS 2845.1 or AS 2845.2.

SUBMITTING FORM

Please submit this form with the photos and provide all billing information for the funding company. If no billing information is provided we will put the quote into the clients name.

OR if the client is DVA please submit this form and photos with the DOF and ATI.

Submit via email to ot@thebidetshop.com.au